



## Datasheet of the High Voltage MEZ Stepper Servo Drive

### ***MEZ-2DH1280***



**70-130VAC, 8.0A Peak, Closed-loop, No Tuning**

Version 1.4  
[http://  
stepper.motorsmfg.com](http://stepper.motorsmfg.com)

©2015 China Stepper Motor Inc.

## China Stepper Motor Inc. *Features*

- Hybrid servo control technology to combine advantages of open-loop stepper systems and brushless servo systems
- Closed-loop controls to eliminate lose of steps, stall or movement synchronization
- High starting torque and quick response
- Smooth motor movement with no vibration
- Excellent respond time, quick acceleration, and very high high-speed torque (30% over open-loop)
- Load-dependent dynamic current output from drive to motor to significantly motor heating deduction
- Input voltage from 70 to 130 VAC; MAX 8.0A peak current output from drive to motor
- Micro step resolution value from 200-51,200 (increased by 1) via software configuration
- Isolated control inputs of Pulse, Direction and Enable
- No tuning for plug and play setup
- On-board HMI for easy setup and configuration
- In-position and fault outputs to external motion controllers for complete system controls.
- Over voltage, over-current, and position-error protection
- Servo control for stepper motors with encoders up to NEMA 42

## *Description*

By taking direct 110 / 120 or 220 / 230 VAC input, China Stepper Motor Inc. MEZ series high voltage stepper servo drives can power large NEMA 34 and 42 MEZ servo motors and offer huge torque to applications with motion control systems.

China Stepper Motor Inc. MEZ series servo drives are based on the latest DSP technology and MotionKing's advanced control algorithm of combing brushless servo and stepper systems. They are featured with closed position loop, offering huge torque, excellent acceleration & quick response, no torque reservation, high standstill stiffness, extra low noise & heating, smooth motor movement, no hunting, no overshooting for almost zero settling time, and no tuning for almost all applications.

## *Applications*

Due to combining the features of both brushless servo drives and stepper drives, China Stepper Motor Inc. MEZ series servo drives are suitable for both upgrading conventional stepper systems, and replacing brushless servo systems which have closed loop and high torque requirements.

China Stepper Motor Inc. MEZ series servo drives can also be implemented as high performance open loop stepper drives with direct 110 / 120 and / or 220 /230 VAC input.

China Stepper Motor Inc. MEZ servo drives and matching MEZ servo motors have been successfully implemented by many OEM clients in applications such as CNC routers, plasma, milling machines, engravers, packaging machines, printing equipments.

China Stepper Motor Inc. **Specifications**

**Electrical Specifications**

Parameters	MEZ-2DH1280
Operating Voltage	70 - 130 VAC (or 100 - 184 VDC)
Maximum Continuous Current	8.0 A
MAX Step Frequency	200KHz or 500KHz (Software Configuration)
Step, Direction and Enable Voltage	5 – 24 V
Logic Signal Input Current	7 – 20 mA

**Control Specifications**

Parameters	MEZ-2DH1280
Command Input	Step/Direction, CW/CCW
Enable/Disable Input	Differential
Alarm Signal Output	Isolated OC Output
Configuration Interface	On-board HMI or RS232 communication
Regeneration Resistor	No

**Mechanical Specifications**

Parameters	MEZ-2DH1280
Size	180mm * 140mm* 70mm
Weight	1500 g

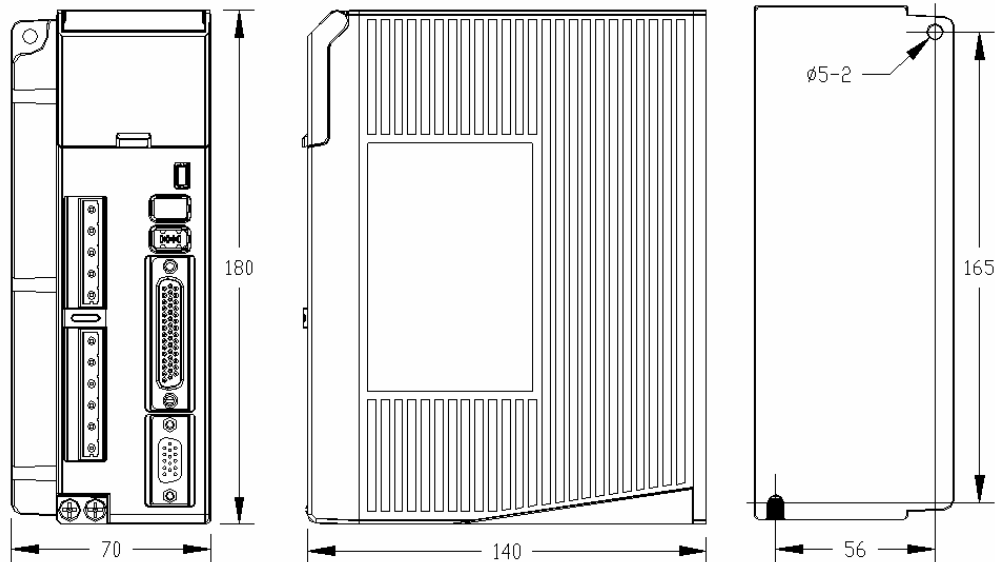

**China Stepper Motor Inc. Operating Environment**

Cooling	Natural cooling or Forced cooling
Ambient Temperature	0 – 40 °C
Humidity	40% RH to 90% RH, No Condensation
Vibration	5.9 m/s <sup>2</sup> MAX
Storage Temperature	-20 °C to 80 °C

**Drive Appearance and Interfaces**

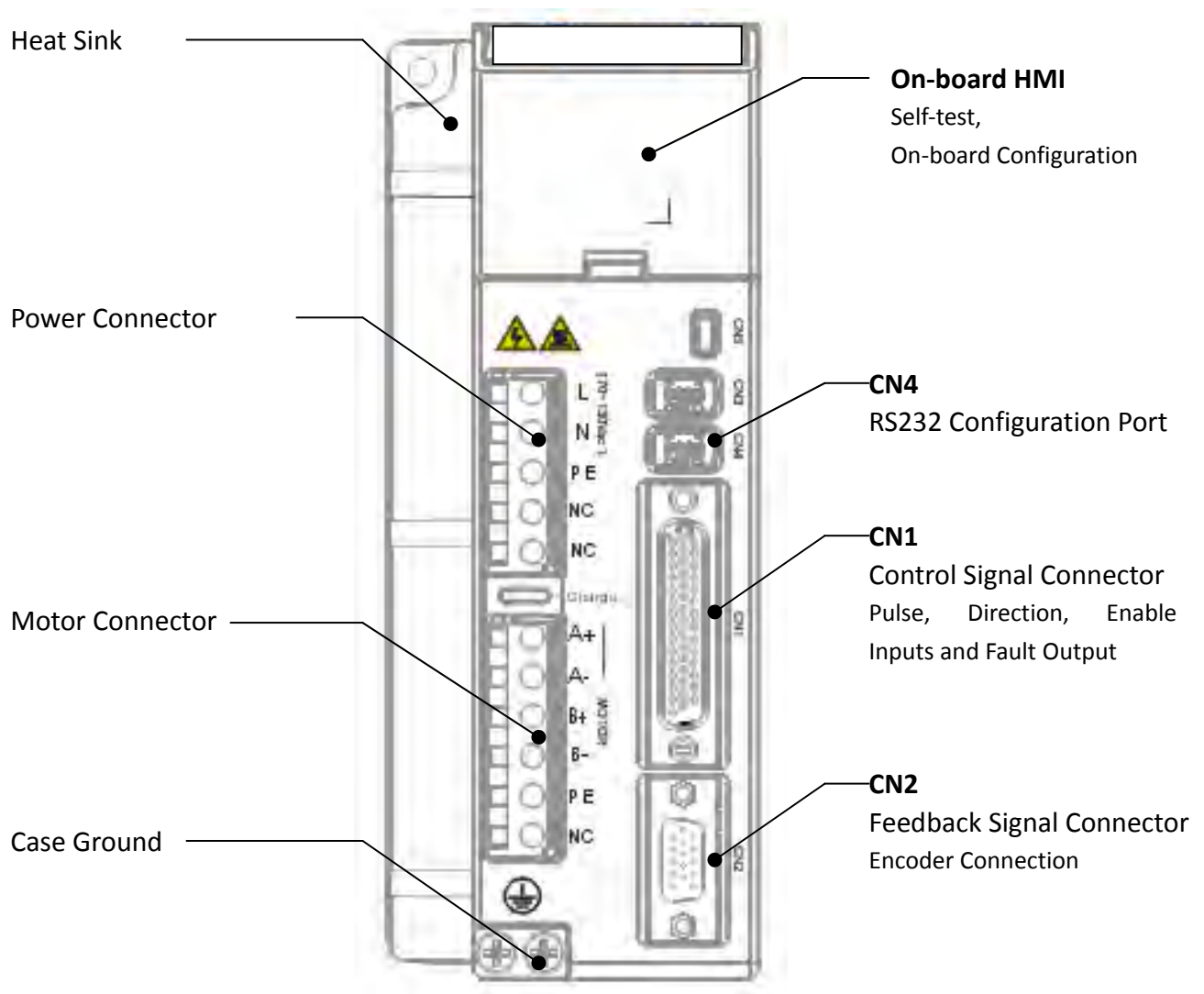

**China Stepper Motor Inc. *Connectors and Pin Assignments***

<b>CN1 – Control Signal Connector</b>			
<b>D-Sub, 26 Pin, Female</b>			
Pin	Name	I/O	Description
1	NC	-	No connection.
2	NC	-	No Connection.
3	PUL+	I	Pulse signal: In single pulse (pulse/direction) mode, this input represents pulse signal, each rising or falling edge active (software configurable); In double pulse mode (software configurable), this input represents clockwise (CW) pulse, active both at high level and low level. 5-24V when PUL-HIGH, 0-0.5V when PUL-LOW. For reliable response, pulse width should be longer than 2.5uS(200K bandwidth) or 1uS(500K bandwidth)
4	PUL-	I	
5	DIR+	I	Direction Signal: In single-pulse mode, this signal has low/high voltage levels, representing two directions of motor rotation. In double-pulse mode (software configurable), this signal is counter-clock (CCW) pulse, active both at high level and low level. For reliable motion response, DIR signal should be ahead of PUL signal by 5μs at least. 5-24V when DIR-HIGH, 0-0.5V when DIR-LOW. The direction signal's polarity is software configurable.
6	DIR-	I	
7	ALM+	O	Alarm Signal: OC (Open Collector) output signal, activated when one of the following protection is activated: over-voltage, over current, braking error and position following error. They can sink or source MAX 100mA current at 5V. The active impedance of alarm signal is software configurable.
8	ALM-	O	
9	NC	-	No connection.
10	NC	-	No connection.
11	ENA+	O	Enable Signal: This signal is used for enabling/disabling the driver. By default, high level (NPN control signal) for enabling the driver and low level for disabling the driver. It is usually left UNCONNECTED (ENABLED). Please note that the PNP and Differential control signals are on the contrary, namely Low level for enabling. The active level of ENA signal is software configurable.
12	ENA-	O	
13	NC	-	No connection.
14	NC	-	No connection.
15	NC	-	No connection.
16	NC	-	No connection.
17	NC	-	No connection.
18	NC	-	No connection.
20	NC	-	No connection.
21	NC	-	No connection.
22	NC	-	No connection.

**China Stepper Motor Inc. *Connectors and Pin Assignments (Continued)***

<b>CN1 – Control Signal Connector</b>			
<b>D-Sub, 26 Pin, Female</b>			
Pin	Name	I/O	Description
23	NC	-	No connection.
24	NC	-	No connection.
25	NC	-	No connection.
26	NC	-	No connection.
27	NC	-	No connection.
28	NC	-	No connection.
29	NC	-	No connection.
30	NC	-	No connection.
31	NC	-	No connection.
32	NC	-	No connection.
33	NC	-	No connection.
34	NC	-	No connection.
35	NC	-	No connection.
36	NC	-	No connection.
37	NC	-	No connection.
38	NC	-	No Connection.
39	NC	-	No connection.
40	NC	-	No connection.
41	NC	-	No connection.
42	NC	-	No connection.
43	NC	-	No connection.
44	NC	-	No connection.
	FG	-	Ground Terminal for shield

**China Stepper Motor Inc. *Connectors and Pin Assignments (Continued)***

<b>CN2 – Feedback Signal (Encoder) Connector</b>			
<b>HDD15, 15Pin, Female</b>			
<b>Pin</b>	<b>Name</b>	<b>I/O</b>	<b>Description</b>
1	EA+	I	Encoder A+ input
2	EB+	I	Encoder B+ input
3	EGND	I/O	+5V output return ground
4	NC	I	No Connection.
5	NC	I	No Connection.
6	FG	I	Ground terminal for shield
7	NC	I	No Connection
8	NC	I	No Connection
9	NC	I	No Connection.
10	NC	I	No Connection.
11	EA-	I	Encoder A- input
12	EB-	I	Encoder B- input
13	+5V	O	+5V power output for encoder, MAX 100mA.
14	NC	I	No Connection.
15	NC	I	No Connection.

<b>CN4 – RS232 Communication Connector</b>			
<b>RS232</b>		Can be connected to PC for drive configuration or servo tuning. Recommended twisted shielded cable and cable length < 2 meter.	
<b>Pin</b>	<b>Name</b>	<b>I/O</b>	<b>Description</b>
1	GND	GND	Ground.
2	TxD	O	RS232 transmit.
3	+5V	O	Reserved +5V power output ( Note: Do not connect it to RS232 port)
4	RxD	O	RS232 receive.
5	NC	-	NC
6	NC	-	NC

**China Stepper Motor Inc. *Connectors and Pin Assignments (Continued)***

Power Connector:			
Pin	Name	I/O	Description
1	L	I	Power supply input connected to 70- 130VAC.
2	N	I	
3	PE	-	Case ground
4	NC	-	No connection.
5	NC	-	No connection.

Motor Connector			
Pin	Name	I/O	Description
1	A+	O	Motor phase A+
2	A-	O	Motor phase A-
3	B+	O	Motor phase B+
4	B-	-	Motor phase B-
5	PE	-	Case ground
6	NC	-	No connection



China Stepper Motor Inc. **Connector Pin-Out**

**CN1 – Control Signal Connector**

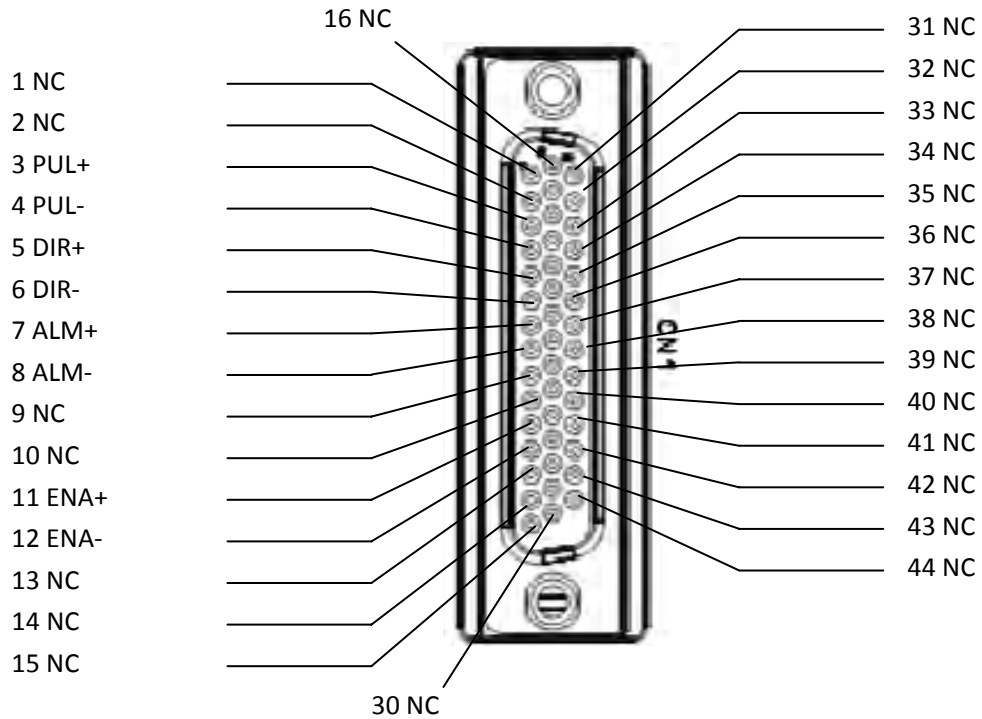

**CN2 – Feedback Signal Connector**

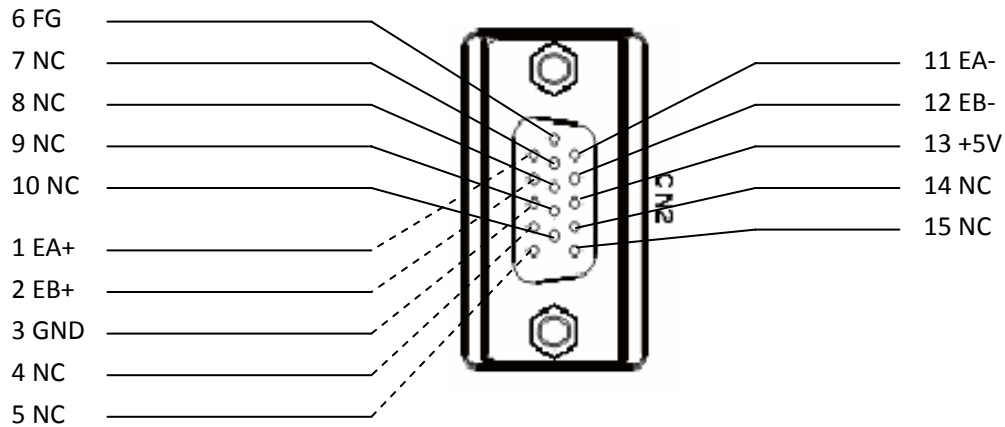

China Stepper Motor Inc. *Connector Pin-Out*  
(Continued)

**CN4 – RS232 & RS485 Connector**

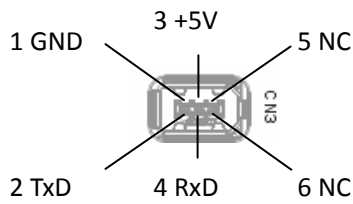

**CN5 –Power Connector**



**CN6 – Motor Connector**

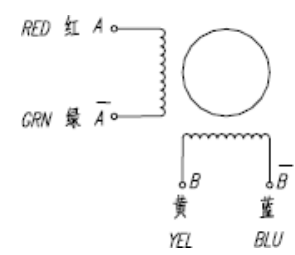

*Easy Servo Motors*

	MEZ-M2-3408-E10	MEZ-M2-3412-E10	Wiring Diagram
Step Angle (°)	1.8	1.8	
Holding Torque (N.m)	8.0	12.0	
Phase Current (A)	7.0	7.0	
Phase Resistance (Ohm)	0.38	0.45	
Phase Inductance (mH)	3.2	5.2	
Shaft Inertia (g.cm <sup>2</sup> )	-	-	
Weight (Kg)	4.0	5.5	
Encoder (lines / Rev.)	1000	1000	

*Typical Connections*

China Stepper Motor Inc.

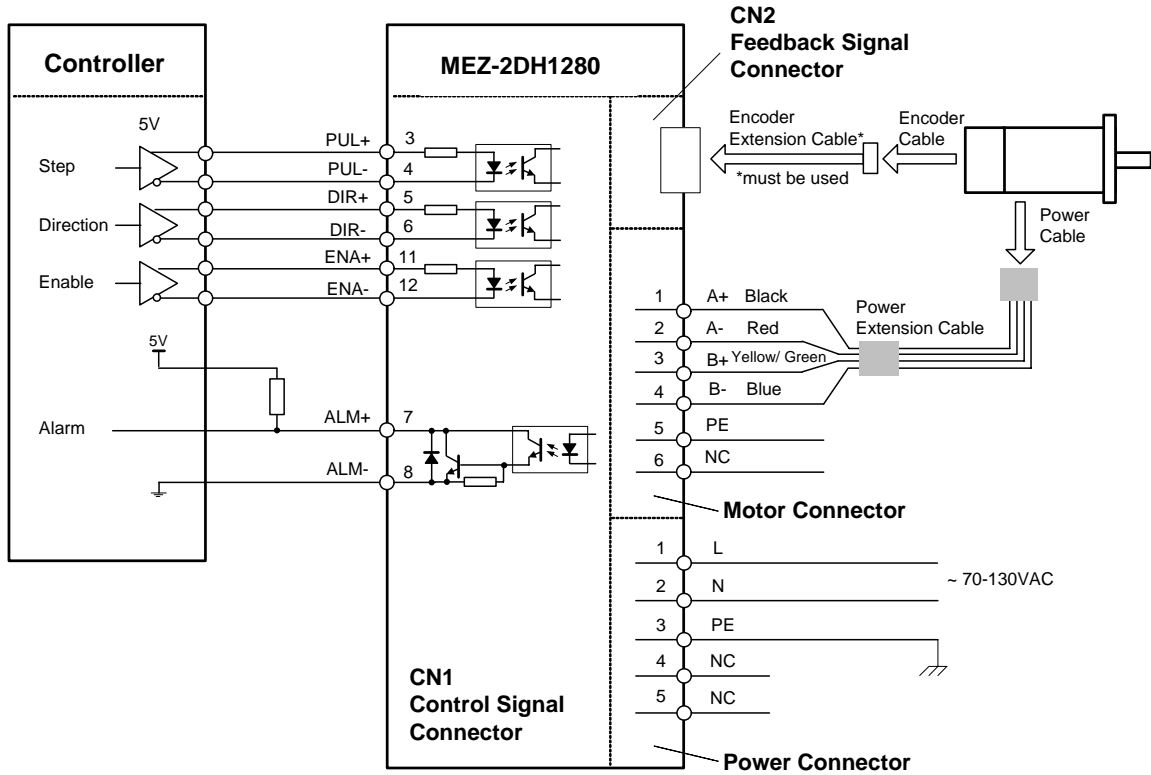

Connections to controller of differential output

Typical Connections (Continued)

China Stepper Motor Inc.

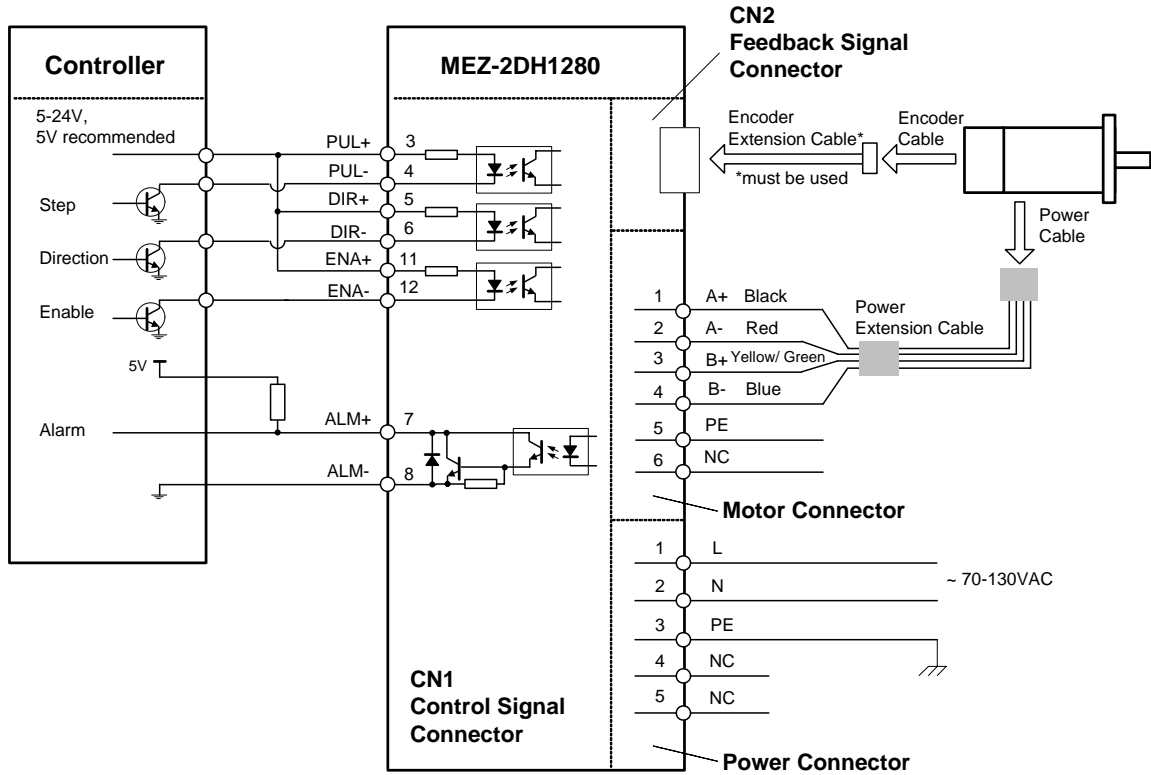

Connection to controller of sinking output

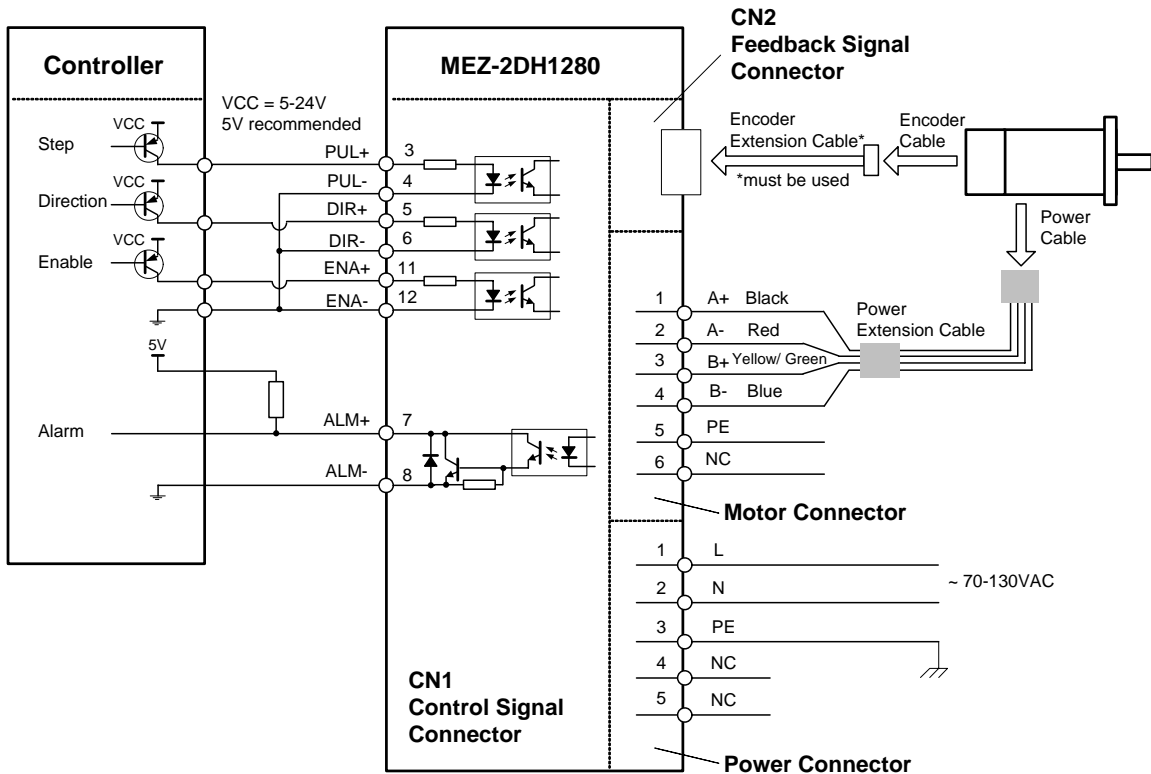

Connection to controller of sourcing output