

User's Manual

For

2L130M

High Performance & Low Noise Microstepping Driver

Version 1.0

©2009 All Rights Reserved

Attention: Please read this manual carefully before using the driver!



China Stepper Motor Inc..

T: +86-755-33813188 F: +86-755-33813336

Web site: stepper.motorsmfg.com E-Mail: inquiry-motor@made-parts.com

The content in this manual has been carefully prepared and is believed to be accurate, but no responsibility is assumed for inaccuracies.

MotionKing reserves the right to make changes without further notice to any products herein to improve reliability, function or design. MotionKing does not assume any liability arising out of the application or use of any product or circuit described herein; neither does it convey any license under its patent rights of others.

MotionKing's general policy does not recommend the use of its products in life support or aircraft applications wherein a failure or malfunction of the product may directly threaten life or injury. According to MotionKing's terms and conditions of sales, the user of MotionKing's products in life support or aircraft applications assumes all risks of such use and indemnifies MotionKing against all damages.

©2009 by China Stepper Motor Inc. All Rights Reserved

Table of contents

1. Introduction, Features and Applications 1
 Introduction 1
 Features 1
 Applications..... 1
 2. Specifications 1
 Electrical Specifications 1
 Mechanical Specifications 2
 Operating Environment and Other Specifications 2
 Elimination of Heat 2
 3. Pin Assignment and Description..... 3
 Connector P1 Configurations 3
 Connector P2 Configurations 3
 4. Control Signal Connector (P1) Interface 4
 5. Connecting the Motor 4
 Connections to 4-lead Motors..... 5
 Connections to 6-lead Motors..... 5
 Half Coil Configurations 5
 Full Coil Configurations 5
 Connections to 8-lead Motors..... 6
 Series Connections 6
 Parallel Connections 6
 6. Power Supply Selection..... 7
 Selecting Supply Voltage 7
 7. Selecting Microstep Resolution and Driver Output Current 7
 Microstep Resolution Selection 7
 Current Settings 8
 Dynamic Current Setting 8
 Standstill Current 9
 8. Wiring Notes..... 9
 9. Typical Connection..... 10

10. Sequence Chart of Control Signals..... 10
 11. Protection Functions 11
 Over-voltage and Short-voltage Protections 11
 Short Circuit Protection 11
 Wrong Motor Connection Protection 11
 Over temperature Protection..... 12
 12. Frequently Asked Questions 12
 Problem Symptoms and Possible Causes 12

1. Introduction, Features and Applications

Introduction

The 2L130M is a high performance and low noise microstepping driver based on pure-sinusoidal current control technology. It's suitable for driving 2-phase and 4-phase hybrid stepping motors. By using advanced bipolar constant-current chopping technique, the 2L130M can output more torque than other drivers at high speed. The microstep capability allows stepping motors to run at higher smoothness, less vibration and lower noise. Its pure-sinusoidal current control technology allows coil current to be well controlled with relatively small current ripple, therefore smaller motor noise and less motor heating can be achieved. In addition, the 2L130M has a built-in EMI filter which can make the driver operate with higher reliability.

Features

- High quality, cost-effective
- Low motor noise and heating
- Supply voltage up to 220VAC (310VDC)
- Output current up to 8.2A(5.86 ARMS)
- TTL compatible and Opto-isolated inputs
- Automatic idle-current reduction
- Input frequency up to 200KHz
- 15 microstep resolutions selectable
- Suitable for 2-phase and 4-phase stepping motors
- DIP switch microstep & current settings
- Support PUL/DIR & CW/CCW modes

Applications

Suitable for large and medium automation machines and equipments, such as engraving machines, labeling machines, cutting machines, laser phototypesetting systems, plotting instruments, NC machines, pick-place devices, and so on. Particularly adapt to the applications desired with low motor noise, low motor heating, high speed and high precision.

2. Specifications

Electrical Specifications (25°C/77°F)

Parameters	2L130M			Unit
	Min	Typical	Max	
Output current	0.7 (0.5A RMS)	-	8.2(5.86A RMS)	A
Supply voltage	150(210)	180(250)	220(310)	VAC(VDC)
Logic signal current	7	10	16	mA
Pulse input frequency	0	-	200	KHz
Isolation resistance	500			MΩ

Mechanical Specifications (unit: mm [inch])

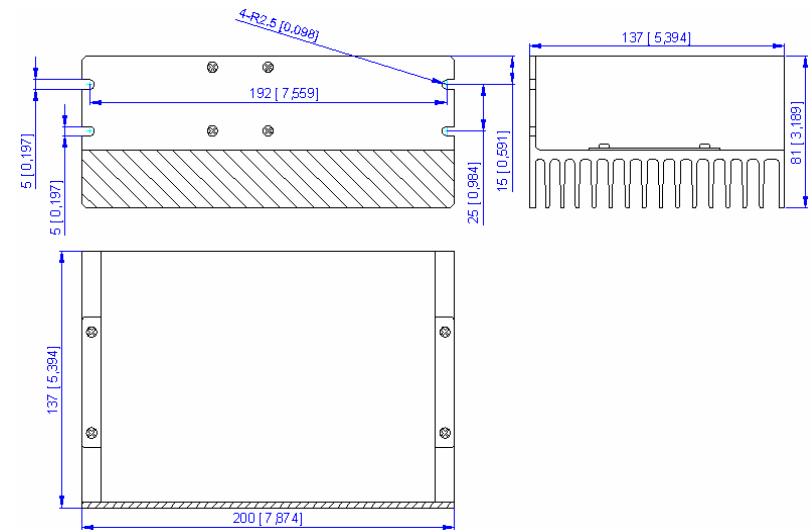

Figure 1: Mechanical specifications

Operating Environment and Other Specifications

Cooling	Natural Cooling or Forced cooling	
Operating Environment	Environment	Avoid dust, oil fog and corrosive gases
	Ambient Temperature	0°C — 50°C (32°F — 122°F)
	Humidity	40%RH — 90%RH
	Operating Temperature	70°C (158°F) Max
	Vibration	5.9m/s ² Max
Storage Temperature	-20°C — 65°C (-4°F — 149°F)	
Weight	Approx. 1.0 kg (35.25 oz)	

Elimination of Heat

- Driver's reliable working temperature should be <70°C(158°F), and motor working temperature should be <80°C(176°F);
- Forced cooling the driver if it's necessary.

3. Pin Assignment and Description

The 2L130M has two connectors, connector P1 for control signals connections, and connector P2 for power and motor connections. The following tables are brief descriptions of the two connectors of the 2L130M. More detailed descriptions of the pins and related issues are presented in section 4, 5, 9.

Connector P1 Configurations

Pin Function	Details
PUL+(+5V)	Pulse signal: In single pulse (pulse/direction) mode, this input represents pulse signal, effective for each rising edge; 4-5V when PUL-HIGH, 0-0.5V when PUL-LOW. In double pulse mode (pulse/pulse), this input represents clockwise (CW) pulse, effective for high level. For reliable response, pulse width should be longer than 1.2μs. Series connect resistors for current-limiting when +12V or +24V used.
PUL-(PUL)	
DIR+(+5V)	DIR signal: In single-pulse mode, this signal has low/high voltage levels, representing two directions of motor rotation; in double-pulse mode(set by inside jumper), this signal is counter-clock (CCW) pulse, effective for high level. For reliable motion response, DIR signal should be ahead of PUL signal by 5μs at least. 4-5V when DIR-HIGH, 0-0.5V when DIR-LOW. Please note that motion direction is also related to motor-driver wiring match. Exchanging the connection of two wires for a coil to the driver will reverse motion direction.
DIR-(DIR)	
ENA+(+5V)	Enable signal: This signal is used for enabling/disabling the driver. High level (NPN control signal, PNP and Differential control signals are on the contrary, namely Low level for enabling.) for enabling the driver and low level for disabling the driver. Usually left UNCONNECTED (ENABLED) .
ENA-(ENA)	
FAULT+	Fault signal positive: FAULT+ is an optocoupler output from open-collector circuit, maximum permitted input voltage is 30VDC; maximum output current 20mA. It generally can be serial connected to PLC input terminal.
FAULT-	Fault signal negative.

Connector P2 Configurations

Pin Function	Details
PE	Ground terminal. Recommend connect this port to the ground for better safety.
AC	AC power supply inputs. Recommend use isolation transformers with theoretical output voltage of 150~220 VAC.
A+, A-	Motor phase A.
B+, B-	Motor phase B.

4. Control Signal Connector (P1) Interface

The 2L130M can accept differential and single-ended input signals (including open-collector and PNP output). The 2L130M has 3 optically isolated logic inputs which are located on connector P1 to accept line driver control signals. These inputs are isolated to minimize or eliminate electrical noises coupled onto the drive control signals. Recommend use line driver control signals to increase noise immunity of the driver in interference environments. In the following figures, connections to open-collector and PNP signals are illustrated.

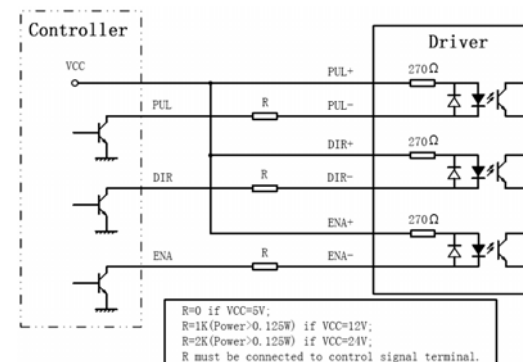

Figure 2: Connections to open-collector signal (common-anode)

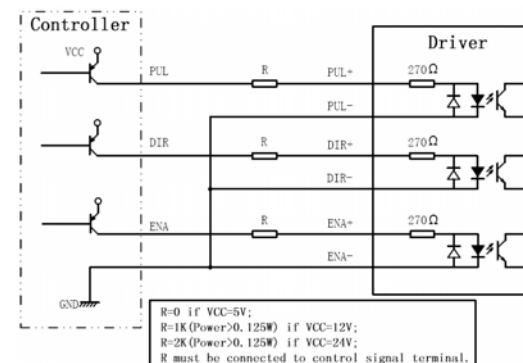

Figure 3: Connection to PNP signal (common-cathode)

5. Connecting the Motor

The 2L130M can drive 2-phase and 4-phase hybrid stepping motors.

China Stepper Motor Inc.

Connections to 4-lead Motors

4 lead motors are the least flexible but easiest to wire. Speed and torque will depend on winding inductance. In setting the driver output current, multiply the specified phase current by 1.4 to determine the peak output current.

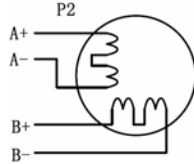

Figure 4: 4-lead Motor Connections

Connections to 6-lead Motors

Like 8 lead stepping motors, 6 lead motors have two configurations available for high speed or high torque operation. The higher speed configuration, or half coil, is so described because it uses one half of the motor's inductor windings. The higher torque configuration, or full coil, uses the full windings of the phases.

Half Coil Configurations

As previously stated, the half coil configuration uses 50% of the motor phase windings. This gives lower inductance, hence, lower torque output. Like the parallel connection of 8 lead motor, the torque output will be more stable at higher speeds. This configuration is also referred to as half chopper. In setting the driver output current multiply the specified per phase (or unipolar) current rating by 1.4 to determine the peak output current.

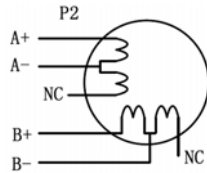

Figure 5: 6-lead motor half coil (higher speed) connections

Full Coil Configurations

The full coil configuration on a six lead motor should be used in applications where higher torque at lower speeds is desired. This configuration is also referred to as full copper. In full coil mode, the motors should be run at only 70% of their rated current to prevent over heating.

China Stepper Motor Inc.

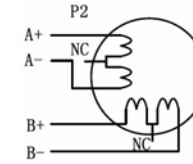

Figure 6: 6-lead motor full coil (higher torque) connections

Connections to 8-lead Motors

8 lead motors offer a high degree of flexibility to the system designer in that they may be connected in series or parallel, thus satisfying a wide range of applications.

Series Connections

A series motor configuration would typically be used in applications where a higher torque at lower speeds is required. Because this configuration has the most inductance, the performance will start to degrade at higher speeds. In series mode, the motors should also be run at only 70% of their rated current to prevent over heating.

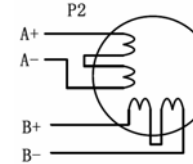

Figure 7: 8-lead motor series connections

Parallel Connections

An 8 lead motor in a parallel configuration offers a more stable, but lower torque at lower speeds. But because of the lower inductance, there will be higher torque at higher speeds. Multiply the per phase (or unipolar) current rating by 1.96, or the bipolar current rating by 1.4, to determine the peak output current.

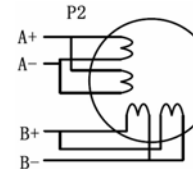

Figure 8: 8-lead motor parallel connections

China Stepper Motor Inc.

6. Power Supply Selection

The 2L130M can match large and medium size stepping motors (from NEMA size 34 to 42) made by MotionKing or other motor manufactures around the world. To achieve good driving performances, it is important to select supply voltage and output current properly. Generally speaking, supply voltage determines the high speed performance of the motor, while output current determines the output torque of the driven motor (particularly at lower speed).

Attention: For safety and to improve reliability, it is recommended to use isolation transformer instead of directly use network source to supply the 2L130M. Recommend use isolation transformers with theoretical output voltage of 150~220VAC or 210~310VDC, leaving room for power fluctuation and back-EMF. And the power of the isolation transformer should larger than 500 watts.

Selecting Supply Voltage

The 2L130M can actually operate within 80~220VAC or 112~310VDC, including power input fluctuation and back EMF voltage generated by motor coils during motor shaft deceleration. Higher supply voltage can increase motor torque at higher speeds, thus helpful for avoiding losing steps. However, higher voltage may cause bigger motor vibration at lower speed, and it may also cause over-voltage protection or even driver damage. Therefore, it is suggested to choose only sufficiently high supply voltage for intended applications, and it is suggested to use power supplies with theoretical output voltage of 150~220VAC or 210~310VDC, leaving room for power fluctuation and back-EMF. If the motion speed requirement is low, it's better to use lower supply voltage to decrease noise, heating and improve reliability.

7. Selecting Microstep Resolution and Driver Output Current

This driver uses a 8-bit DIP switch to set microstep resolution, motor operating current and control signal mode as shown in the following figure:

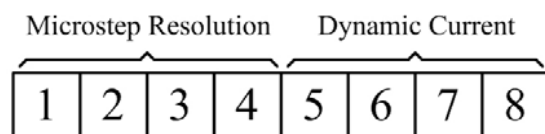

Microstep Resolution Selection

Microstep resolution is set by SW1, 2, 3, 4 of the DIP switch as shown in the following table:

China Stepper Motor Inc.

Steps/rev.(for 1.8°motor)	SW1	SW2	SW3	SW4
400	ON	ON	ON	ON
400	OFF	ON	ON	ON
800	ON	OFF	ON	ON
1600	OFF	OFF	ON	ON
3200	ON	ON	OFF	ON
6400	OFF	ON	OFF	ON
12800	ON	OFF	OFF	ON
25600	OFF	OFF	OFF	ON
1000	ON	ON	ON	OFF
2000	OFF	ON	ON	OFF
4000	ON	OFF	ON	OFF
5000	OFF	OFF	ON	OFF
8000	ON	ON	OFF	OFF
10000	OFF	ON	OFF	OFF
20000	ON	OFF	OFF	OFF
25000	OFF	OFF	OFF	OFF

Current Settings

For a given motor, higher driver current will make the motor to output more torque, but at the same time causes more heating in the motor and driver. Therefore, output current is generally set to be such that the motor will not overheat for long time operation. Since parallel and serial connections of motor coils will significantly change resulting inductance and resistance, it is therefore important to set driver output current depending on motor phase current, motor leads and connection methods. Phase current rating supplied by motor manufacturer is important in selecting driver current, however the selection also depends on leads and connections.

The latter four bits (SW5, 6, 7, 8) of the DIP switch are used to set the dynamic current. Select a setting closest to your motor's required current.

Dynamic Current Setting

Peak current (A)	RMS (A)	SW5	SW6	SW7	SW8
------------------	---------	-----	-----	-----	-----

China Stepper Motor Inc.

0.7A	0.5A	OFF	OFF	OFF	OFF
1.2A	0.86A	OFF	OFF	OFF	ON
1.72A	1.23A	OFF	OFF	ON	OFF
2.2A	1.57A	OFF	OFF	ON	ON
2.75A	1.96A	OFF	ON	OFF	OFF
3.28A	2.34A	OFF	ON	OFF	ON
3.75A	2.68A	OFF	ON	ON	OFF
4.22A	3.01A	OFF	ON	ON	ON
4.72A	3.37A	ON	OFF	OFF	OFF
5.2A	3.72A	ON	OFF	OFF	ON
5.78A	4.13A	ON	OFF	ON	OFF
6.24A	4.46A	ON	OFF	ON	ON
6.78A	4.84A	ON	ON	OFF	OFF
7.31A	5.22A	ON	ON	OFF	ON
7.81A	5.58A	ON	ON	ON	OFF
8.2A	5.68A	ON	ON	ON	ON

Notes: Due to motor inductance, the actual current in the coil may be smaller than the dynamic current setting, particularly under high speed condition.

Standstill Current

The 2L130M has automatic idle-current reduction function. The current automatically be reduced to 60% of the selected dynamic current setting 0.2 second after the last pulse. Theoretically, this will reduce motor heating to 36% (due to $P=I^2 \cdot R$) of the original value. If the application needs a different standstill current, please contact MotionKing.

8. Wiring Notes

- ◆ In order to improve anti-interference performance of the driver, it is recommended to use twisted pair shield cable.
- ◆ To prevent noise incurred in pulse/dir signal, pulse/direction signal wires and motor wires should not be tied up together. It is better to separate them by at least 10 cm, otherwise the disturbing signals generated by motor will easily disturb pulse direction signals, causing motor

China Stepper Motor Inc.

position error, system instability and other failures.

- ◆ If a power supply serves several drivers, separately connecting the drivers is recommended instead of daisy-chaining.
- ◆ It is prohibited to pull and plug connector P2 while the driver is powered ON, because there is high current flowing through motor coils (even when motor is at standstill). Pulling or plugging connector P2 with power on will cause extremely high back-EMF voltage surge, which may damage the driver.

9. Typical Connection

A complete stepping system should include stepping motor, stepping driver, power supply and controller (pulse generator). A typical connection is shown as figure 9.

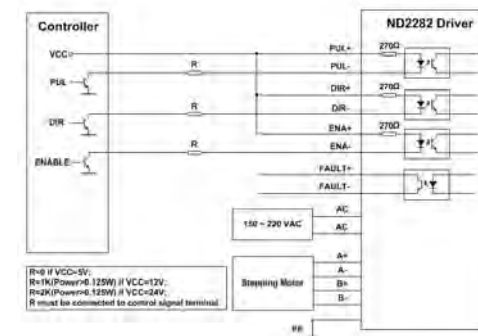

Figure 9: Typical connection

10. Sequence Chart of Control Signals

In order to avoid some fault operations and deviations, PUL, DIR and ENA signals should abide by some rules, shown as following diagram:

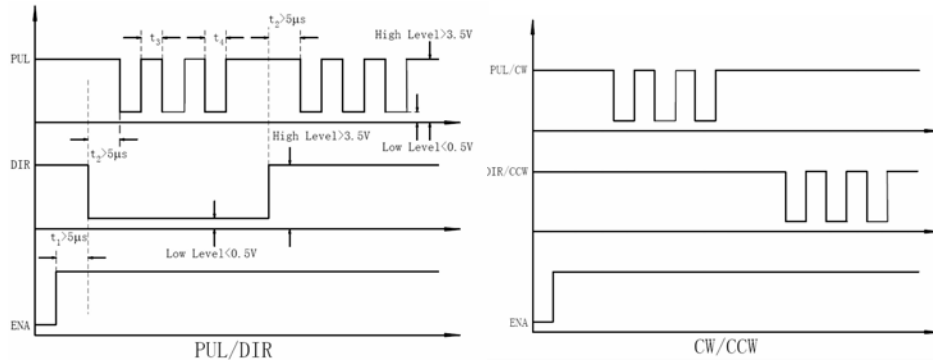

Figure 10: Sequence chart of control signals

Remark:

- (1) t1: ENA must be ahead of DIR by at least 5μs. Usually, ENA+ and ENA- are NC (not connected). See “Connector P1 Configurations” for more information.
- (2) t2: DIR must be ahead of PUL effective edge by at least 5μs to ensure correct direction;
- (3) t3: Pulse width not less than 1.5μs;
- (4) t4: Low level width not less than 1.5μs.

11. Protection Functions

To improve reliability, the driver incorporates some built-in protection features.

Over-voltage and Short-voltage Protections

When power supply voltage exceeds 286VAC or 405VDC, over-voltage protection will be activated and the RED ALARM LED will light. When power supply voltage is lower than 56VAC or 80VDC, short-voltage protection will be activated and the RED ALARM LED will light.

Short Circuit Protection

Protection will be activated in case of short circuit between motor coils or between motor coil and ground.

Wrong Motor Connection Protection

Protection will be activated when the motor is connected in a wrong way.

Over temperature Protection

Protection will be activated when driver temperature reaches to 75°C.

When above protections are active, the motor shaft will be free and the RED ALARM LED will light. Reset the driver by repowering it to make it function properly after removing above problems.

12. Frequently Asked Questions

In the event that your 2L130M doesn't operate properly, the first step is to identify whether the problem is electrical or mechanical in nature. The next step is to isolate the system component that is causing the problem. As part of this process you may have to disconnect the individual components that make up your system and verify that they operate independently. It is important to document each step in the troubleshooting process. You may need this documentation to refer back to at a later date, and these details will greatly assist our Technical Support staff in determining the problem should you need assistance.

Many of the problems that affect motion control systems can be traced to electrical noise, controller software errors, or mistake in wiring.

Problem Symptoms and Possible Causes

Symptoms	Possible Problems
Motor is not rotating	No power
	Microstep resolution setting is wrong
	DIP switch current setting is wrong
	Fault condition exists
	The driver is disabled
Motor rotates in the wrong direction	Motor phases may be connected in reverse
The driver in fault	DIP switch current setting is wrong
	Something wrong with motor coil
Erratic motor motion	Control signal is too weak
	Control signal is interfered
	Wrong motor connection
	Something wrong with motor coil

China Stepper Motor Inc.

	Current setting is too small, losing steps
Motor stalls during acceleration	Current setting is too small
	Motor is undersized for the application
	Acceleration is set too high
	Power supply voltage too low
Excessive motor and driver heating	Inadequate heat sinking / cooling
	Automatic current reduction function not being utilized
	Current is set too high